

StreamBlade™ SOE-4-PCI DATA SHEET

FEATURE SUMMARY

- Four Independent Stream Offload Engines
- Two Xilinx XC4VFX60 FPGAs
- Four PowerPC 405 Cores (450 MHz)
- Four 10/100/1000 Ethernet Ports
- 128M x 32 bits DDR2 SDRAM
- 16M x 16 bits ZBT SRAM
- Four LVTTTL/LVCMOS 30-bit I/O via 40-pin ATA connectors
- Four Serial (RS-232)
- PCI 3.0 compliant



STREAM OFFLOAD ENGINE

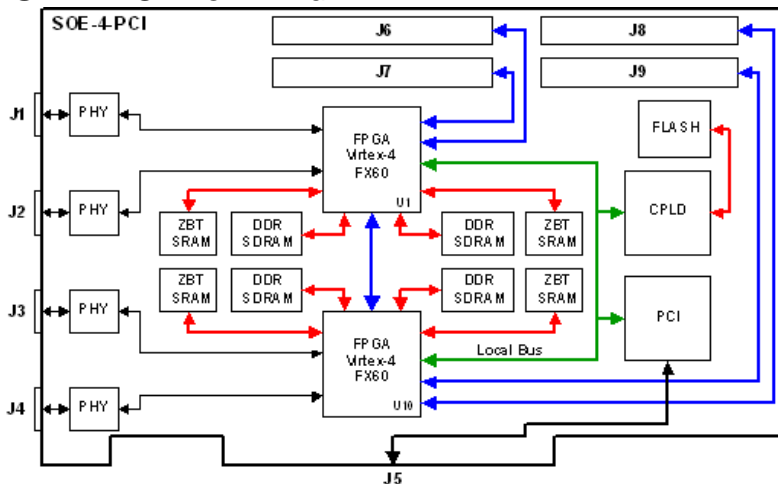

Embedded Systems Design, Inc. (ESD) StreamBlade™ SOE-4-PCI single board computer allows developers to take full advantage of the four independent Stream Offload Engines (SOEs). The StreamBlade™ SOE-4-PCI single board computer is designed to transport real-time streaming data and utilizes ESD's Stream Offload Engine (SOE) technology to provide real-time streaming data paths between distributed processing nodes. The StreamBlade™ SOE-4-PCI's two Xilinx Virtex-4 FX40 FPGAs are capable of implementing four independent SOEs that provide zero-copy, full TCP/IP offload, and 10/100/1000 Ethernet connectivity for each configured 40 Pin ATA connector.

The ESD StreamBlade™ SOE-4-PCI single board computer reduces development time and increases reliability for Communications, Medical, and Industrial applications. The ESD StreamBlade™ SOE-4-PCI single board computer provides users with direct access to each SOE via a 40 pin ATA connector and/or Ethernet RJ-45 connection.

ESD's SOE technology acts to decouple real-time streaming data source and sink processing nodes, allowing real-time processing jitter to occur without data loss.

CONFIGURABILITY

The 40 pin ATA connectors provide access to FPGA pins and allow developers the freedom to customize the connectivity necessary to interface with a variety of real-time streaming data sources and sinks that support interfaces such as Ethernet, RS-232, RS-422, G.703, LVDS, and ECL.

ESD StreamBlade™ single board computers can be configured™ to run without a host. StreamBlade™ single board computers may be configured into any host with available PCI slots including passive PCI back-planes.



SOE-4-PCI SPECIFICATIONS

Feature	Function	Detail
Form Factor	Card Dimension	6.6" x 4.2", 167.64 mm x 106.68 mm (Short Add-In)
	Card Type	PCI 3.0 compliant

ORDERING INFORMATION

Call for pricing and availability: (410) 712-7290.

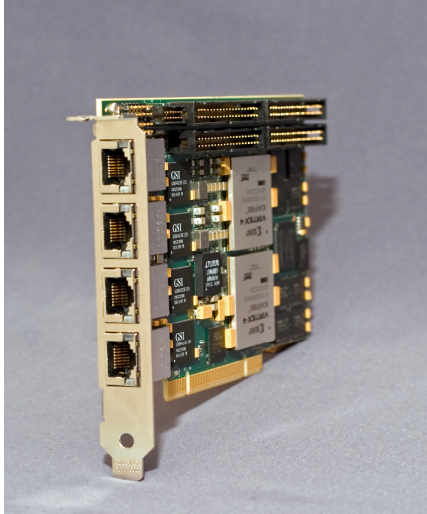

©2007 StreamBlade, StreamBed, and Stream Offload Engine are registered trademarks of Embedded Systems Design, Inc. All other trademarks are the properties of their respective owners. All specifications within this document are subject to change without notice.



Embedded Systems Design, Inc.
6810 Deerpath Road, Suite 300
Elkridge, MD 21075
USA

Phone: (410) 712-7290
Fax: (410) 712-7291
www.embedded-sys.com
www.ESD-StreamBlade.com

Feature	Function	Count	Detail
Bus Interface	PCI	32-bit	33 MHz, target (no master)
	Local	32-bit	33 MHz for PCI Host access to CPLD/FPGA interfaces
	Cross Connect	16/8	16 Single Ended or 8 Differential Signals for inter-FPGA communications
Streaming Processors	FPGA	2	Xilinx XC4VFX60 FPGAs
	CPU	4	PowerPC 405 Cores (450 MHz Max) - Two per FPGA
Memory	DDR2 SDRAM	4	32M X 32 Bits (128M Bytes) - Two per FPGA
	ZBT SRAM	4	4M X 16 Bits (8M Bytes) - Two per FPGA
Non-Volatile Memory	Flash	1	64MB for FPGA Configuration and Power PC Code
I/O - Plate	Ethernet	4	RJ-45 connectors with activity LEDs - Two per FPGA
			Tri-Mode Ethernet MAC Cores (IEEE Std 802.3-2002 compliant) - Two (usable) per FPGA
			Marvell 88E111 Gigabit Ethernet Transceiver - Two per FPGA
I/O - Additional	LVTTL/LVCMOS	4	40-pin ATA connectors (30 available pins, 3.3/2.5 Volt selectable per FPGA) - Two per FPGA
	Serial	4	10-pin headers (RS-232 port) - Two per FPGA
	JTAG	1	4-pin header for FPGA/PPC Debug
Clocks	On-board Oscillator	1	100 MHz - available to both FPGAs
	PCI Bus Clock	1	33MHz - available to both FPGAs
Miscellaneous	LED	8	Four per FPGA

Feature	Function	Value
Power	Quiescent	3.0 Watt
	Operational	8.0 Watt – 2 PPC on 1 FPGA max freq
12.0 Watt – 2x(1 PPC on 1 FPGA max freq)		
Voltage	Board Supply	3.3 Volt - standard (5 Volt option)
Environmental ¹	Temperature	0°C to 70°C - operational
		-40°C to +85°C - storage
	Air Flow	-
	Shock	up to 10g at 10ms - operational
	Vibration	0.25g (5-100Hz) - operational
		2.0g (5-100Hz) - storage
Humidity	0-95% at 40°C non-condensing - operational	
	0-95% at 40°C non-condensing - storage	
Altitude		0-15000 ft (0-4572 m)

¹ preliminary Jan 2007